

Typ Sw

Typ Sw-HD

Axes and width adjustment / Axles and width adjustment / Achsen und Breiteneinstellung

Typ Sw

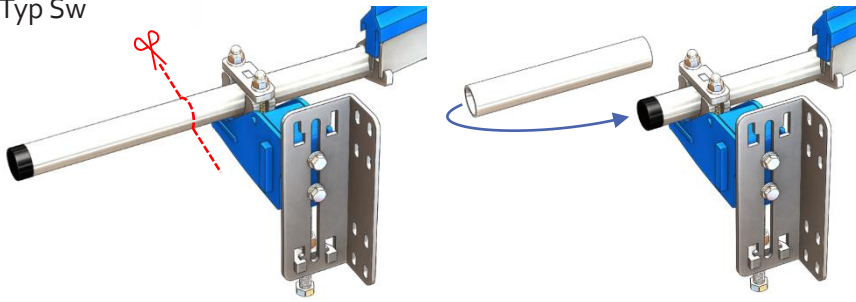

Typ Sw-HD

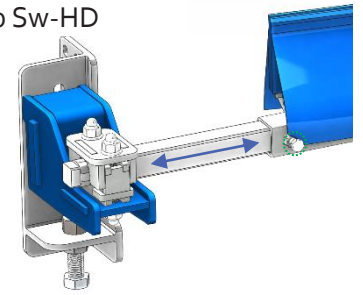

**Angle de
raclage**

**Scraping
angle**

Schabwinkel

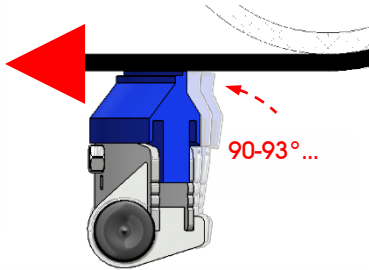

90-93° en marche

Attention : il est différent à l'arrêt

90-93° when running.

Warning: it is different at standstill

90-93° in Gang, Achtung: anders bei Stillstand

BT / BW / BB < 1600

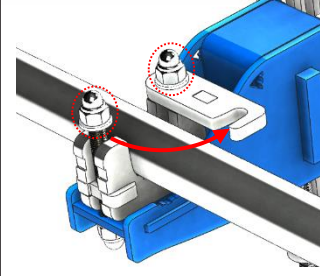

BT / BW / BB ≥ 1600

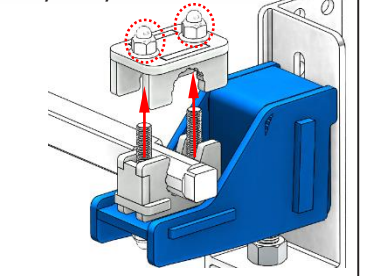

Bande reversible / 2 Ways belts / Reversierbänder

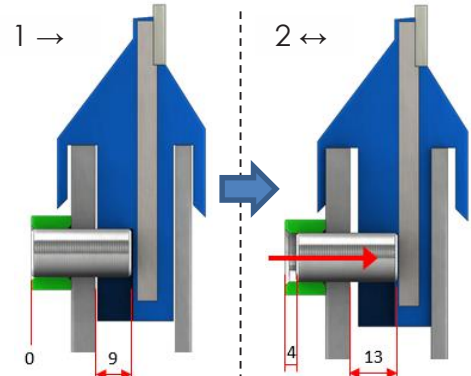
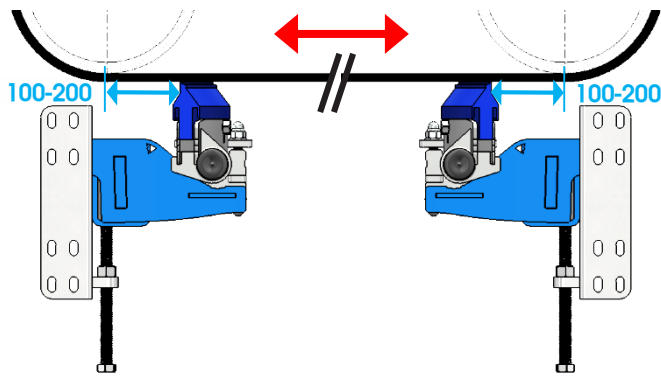

Mise en pression / Pressurization / Druck Einstellung

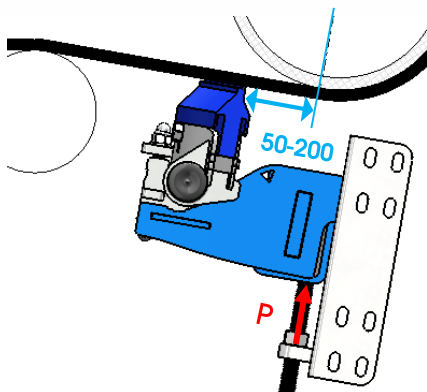

BT	BW	BB	P
400			5
500			6
650			7
800			9
1000			11
1200			13
1400			15
1600			17
1800			19
2000			22

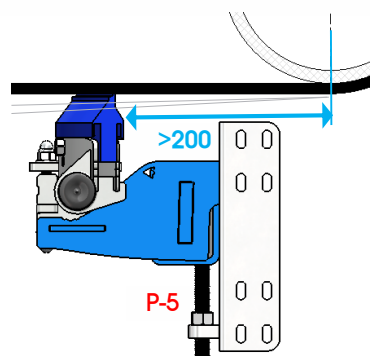

Sans tambour de contrainte
Without tension drum
Ohne Spanntrommel

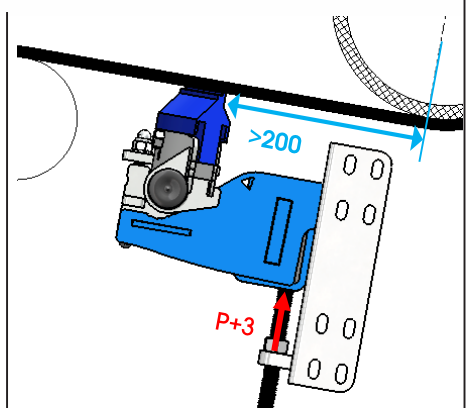

Avec tambour de contrainte
With tension drum
Mit Spanntrommel

Avec ou sans tambour de contrainte
With or without tension drum
Mit oder ohne Spanntrommel

Instructions/Anleitung

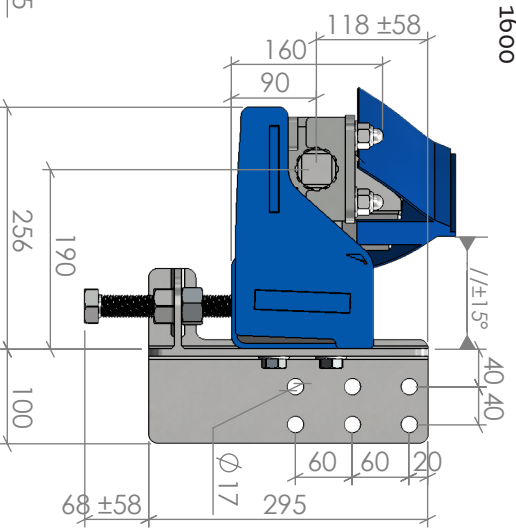
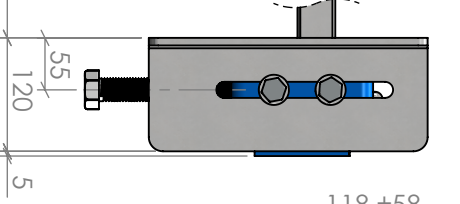
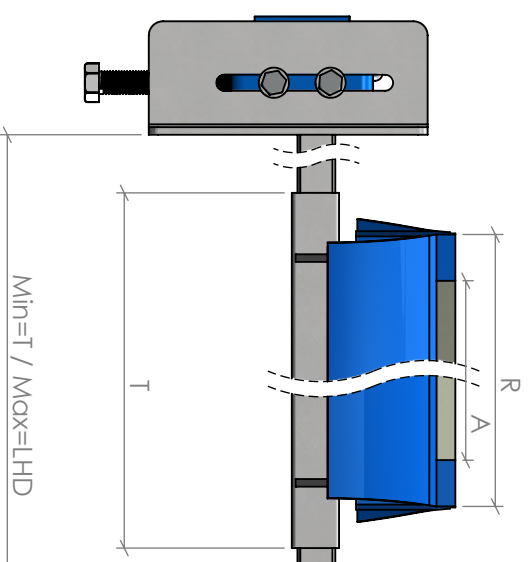
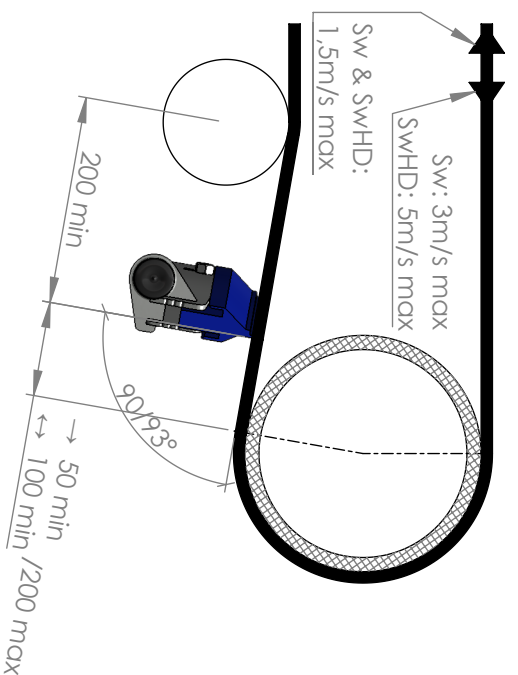
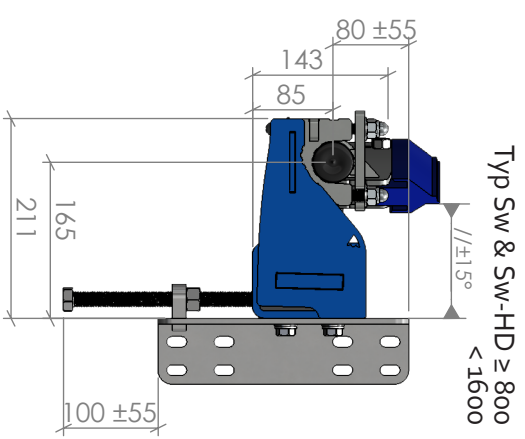
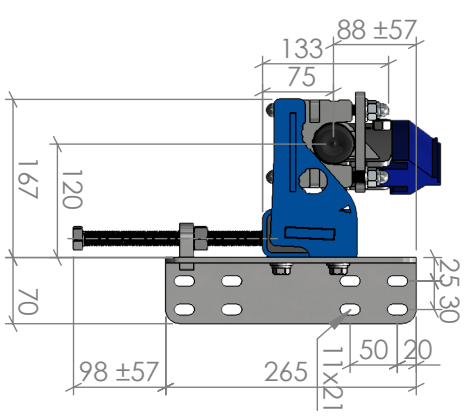
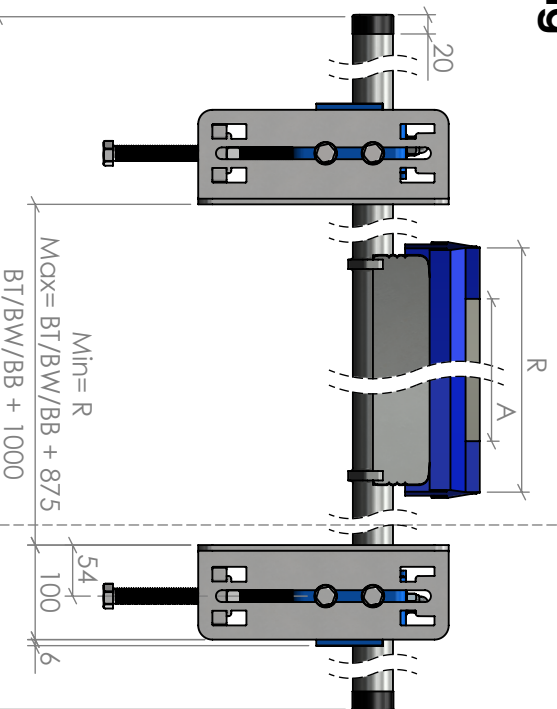
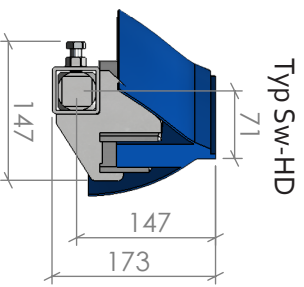
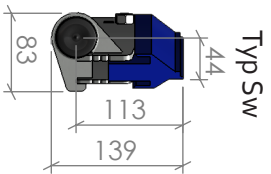

BT/BW/BB	400	500	650	800	1000	1200	1400	1600	1800	2000
R	400	500	630	750	950	1150	1300			
A (Sw-SwHD)	315	395	520	640	800-840	960-1040	1120-1200	1400	1600	1800
LHD					1535	1760	1910	2030	2730	2930
T					1005	1230	1380	1580	1780	1980

T°C min/max	-10	+50
pH min/max	3	11



Typ Sw / Sw-HD

www.wanngo.ch

 Plan N° **151216 141**
 Format A4
 Echelle 1:8